

The Leaders in Portable X-Ray Systems

Products Overview

NDT

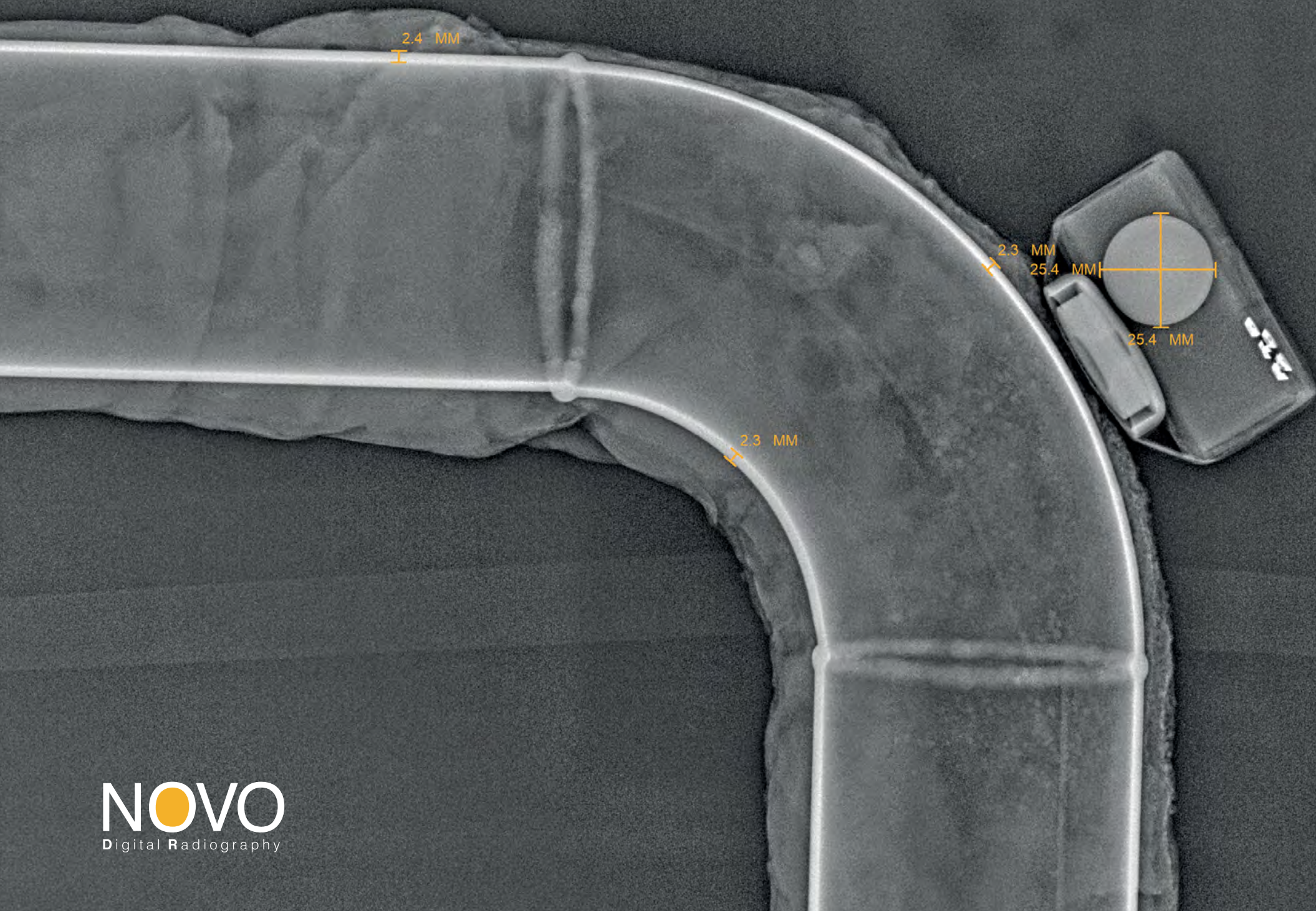

About NOVO DR



NOVO DR Ltd. offers innovative, rugged, and reliable Portable Digital Radiography systems.

Designed and engineered in-house by our highly skilled, professional and experienced team, our products provide superb image quality, are intuitive and easy to use.

Why NOVO?



High Image Quality

Decades of expertise, detectors built specifically for NDT applications and advanced software, all attribute to the highest image quality.



Reliable

Our systems are designed for outdoor operations, so we use the best raw materials; proprietary NOVO cables; MIL-DTL 38999 connectors; rugged Detectors & Wireless Mesh Technology for high signal stability.



Easy to Use

Lightweight Detectors, intuitive NOVO Touch Software and user-friendly system components make NOVO equipment effortless to setup & operate.



Professional Support

Fast response, the expertise of our team and in-house Developers bring you the right solution.

Common Applications

Oil & Gas



Aerospace

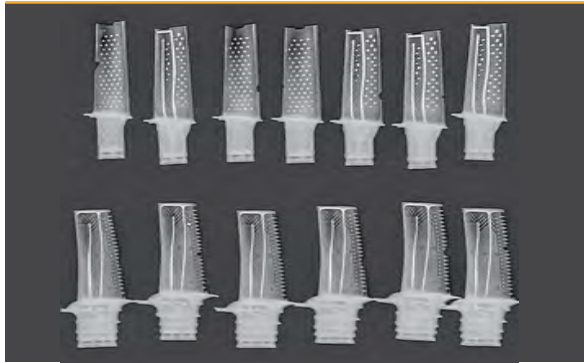

Concrete

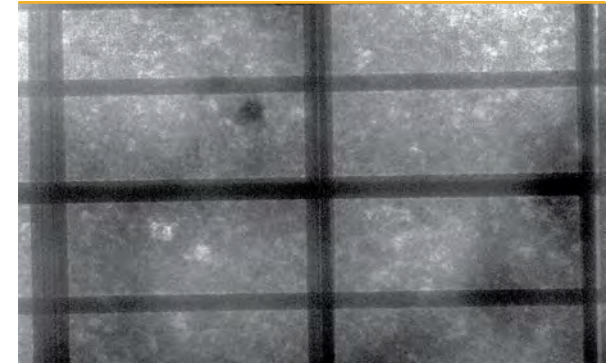

Ship Building

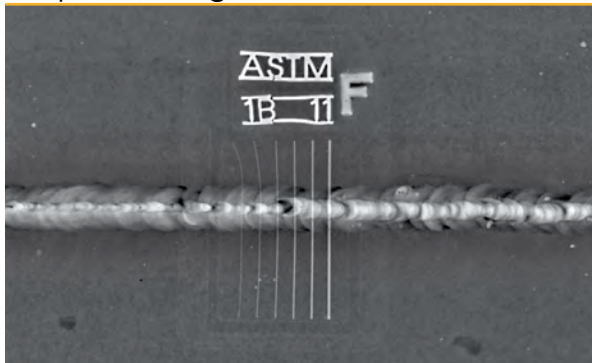

Power Line

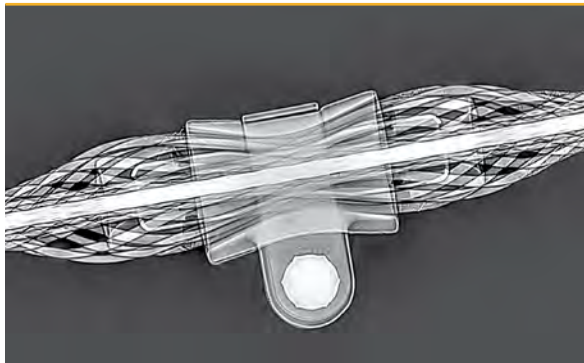

Munition



Art & Archaeology

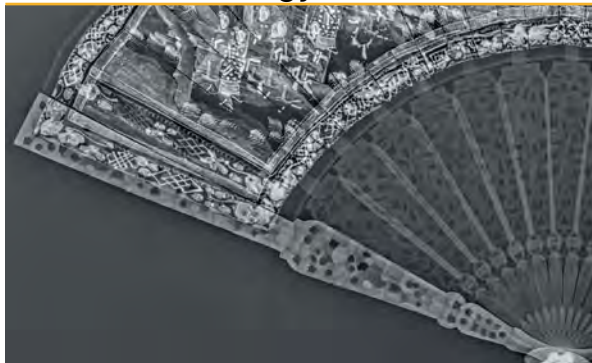

Railways



International Standards



The NOVO Touch Pro Software has numerous tools necessary to support multiple international standards such as:

- ISO 17636-2 Class B
- BOEING 7044 Ver C
- ASME Section V article 2
- ASTM DICONDE

NOVO Wireless Mesh Technology



Unique technology providing unmatched wireless performance:

- High signal stability in crowded RF environments, such as urban locations and areas with strong electromagnetic fields
- Up to 0.6 miles (1000m) LOS between wireless devices; longer range when elevating on tripods - up to 1.8 miles (3km)
- Multiple wireless devices allow for working “around corners”, obstacles and underground operations
- Each wireless unit becomes a relay (repeater), which automatically connects and automatically relays wireless signals efficiently

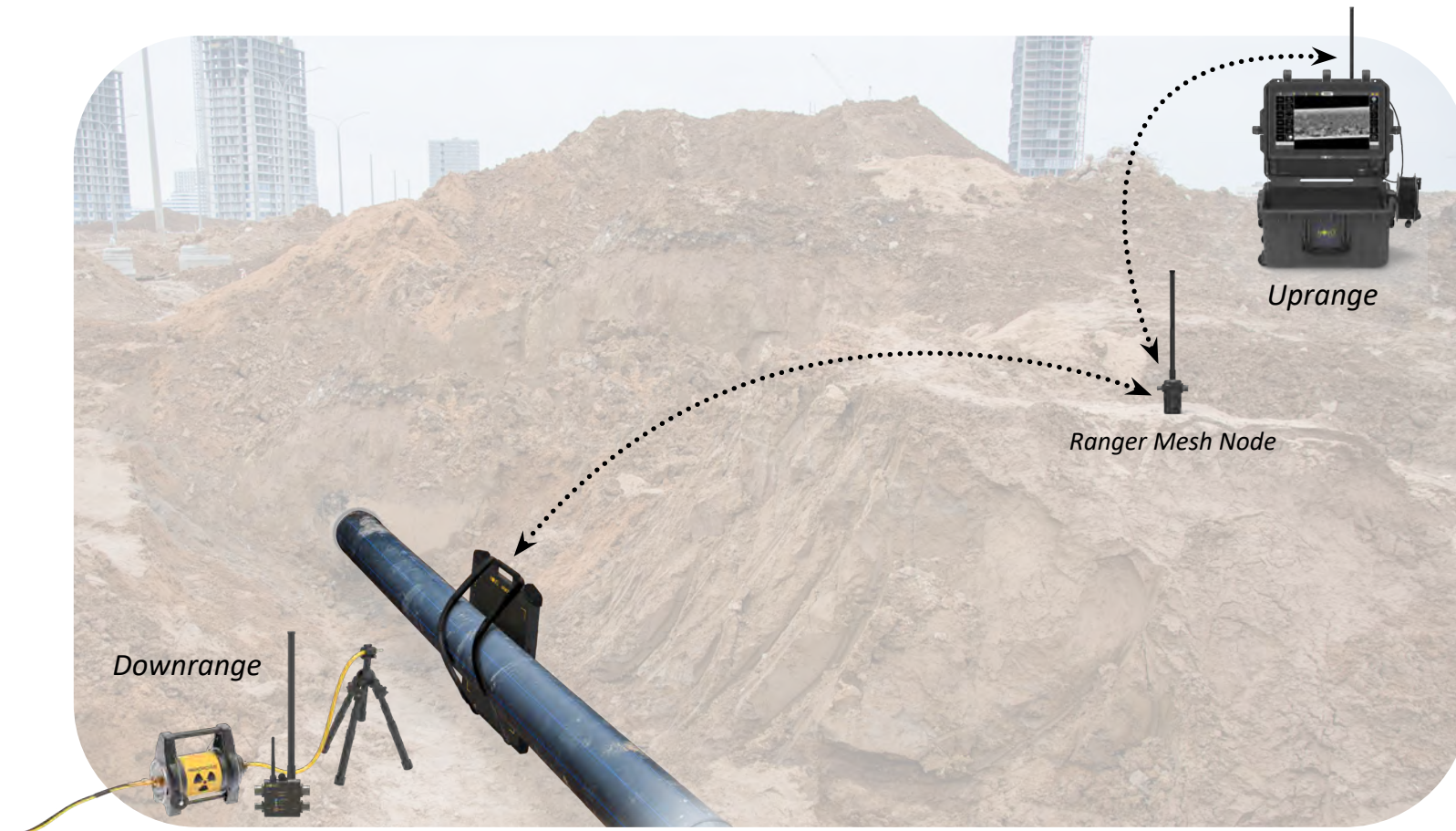

Systems

NOVO offers a wide variety of Systems suitable for various NDT applications. These are our most popular Systems.

For detailed information, please review the specific systems' brochures

Shadow III NDT System

Ultra Compact System - Ideal for hard to reach locations

- Android Phone / Windows tablet operation
- 12SFN Detector - Detector weighs only 2.6 lbs. (1.2kg) with battery
- Imaging just 0.12" (3mm) from bottom & side
- Wired & wireless operation modes
- Full working system from ~8.8 lbs. (4kg), housed in one Backpack
- Includes NOVO Touch Pro full Software package + NOVO Touch Android App



Discovery III System

Top of the Line System in a Rugged Pelican Case

- 10BN/12SFN/12HRN/15WN/18BN/22WN Detector options
- Wired & wireless operation modes
- 21.5" 1500 NIT Sun-Readable touch tablet
- MIL-DTL 38999 connectors
- Industrial X-Ray Source control
- Includes NOVO Touch Pro full Software package



Ultimate III System Large Format Backpack



- 10BN/12SFN/12HRN/15WN/22WN Detector options
- Wired & wireless operation modes
- 10" 1500 NIT touch handheld tablet / Android Phone
- MIL-DTL 38999 connectors
- Supports multi-tablet control & display
- 35m of cable on a lightweight reel
- Includes NOVO Touch Pro full Software package



Laboratory II System Stationary System – Perfect for X-Ray Labs and Cabinets

- 10BN/12SFN/12HRN/15WN/18BN/22WN Detector options
- Wired operation
- MIL-DTL 38999 connectors
- Industrial X-Ray Source control
- Includes NOVO Touch Pro full Software package

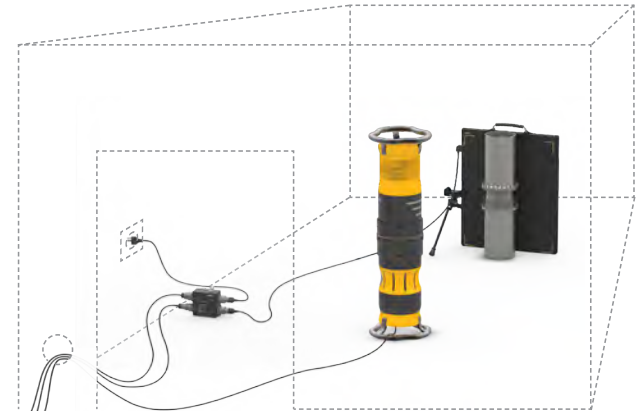

NOVO Touch Pro Software

For detailed information, please review the NOVO Touch Pro Software brochure



The NOVO Touch Pro Software is a proprietary software developed in-house to provide the best user experience and functionality.



The Genie Enhancement Feature

Allows taking a single image, enhancing both easy and hard to penetrate areas on the same image, with just one touch! Improved version - 4 times faster!



Wall Thickness Tool

Automatic measurement calibration- fast, easy & automatic wall thickness measurements.

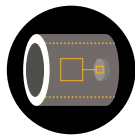

DWT

Simple & intuitive Double Wall Thickness Technique Tool - converting gray levels into material thickness.



Stitching Feature

Stitch multiple images using our Manual or Automatic Stitching features.

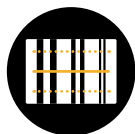

Auto Basic Spatial Resolution Calculator

Select the region of interest and leave the rest to the NOVO SRb calculator.



DICONDE Compliant

Controllers

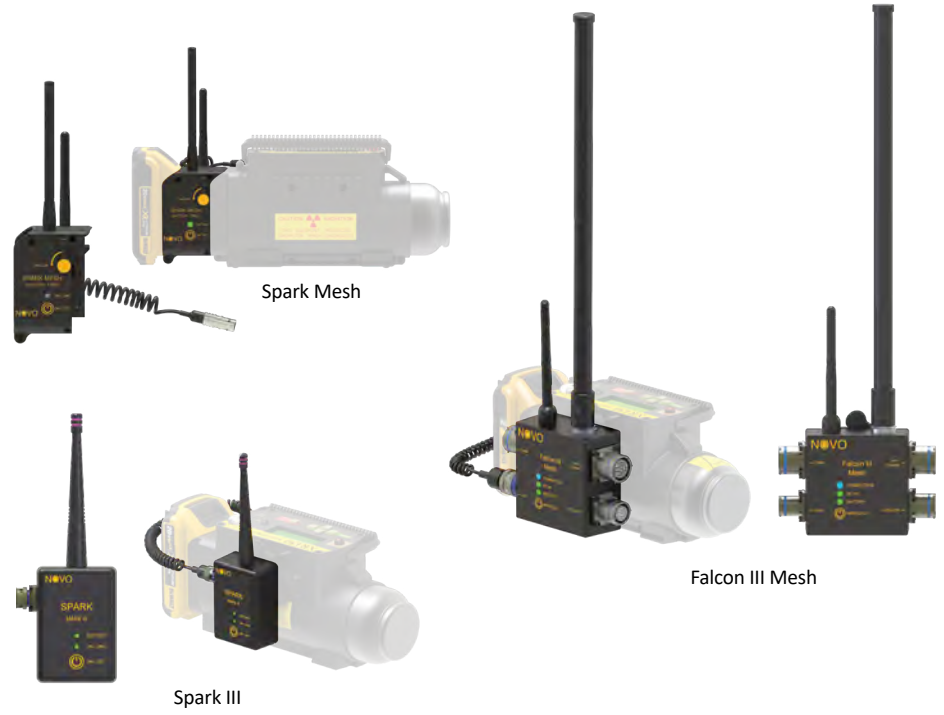

	Spark Mesh	Spark III	Falcon III Mesh
Controller Weight	0.9 lbs. (0.4kg)	0.7 lbs. (0.3kg)	2 lbs. (0.9kg)
Battery	6 hours* battery with 4000 pulses	6 hours built-in battery	6 hours built-in battery
Wireless Range	Up to 0.46 miles (750m) Line of Sight	Up to 0.24 miles (400m) Line of Sight	Up to 0.6 miles (1000m) Line of Sight
AC Connection	X	X	Unlimited operation with AC (POE)
Connectors	DeWalt 20V mount	MIL-DTL 38999 connectors	MIL-DTL 38999 connectors
Golden Sources Support	DeWalt 20V	All	All
Weatherproof	✓	✓	✓
LED Indications	✓	✓	✓
Supports Golden On/Off & Battery Status Info	✓	✓	✓

* Tested with Golden XR150

Detectors

For detailed information, please review the specific systems brochures

The NOVO range of Detectors provide outstanding image quality in a rugged, durable, thin design and are the latest in DR imaging technology.

- Built-in shielding for maximum life span
- High dose resistance
- Dual direction magnetic connector
- Quick removable & rechargeable battery
- Wireless & wired operation
- Specifically designed for fieldwork & harsh weather conditions

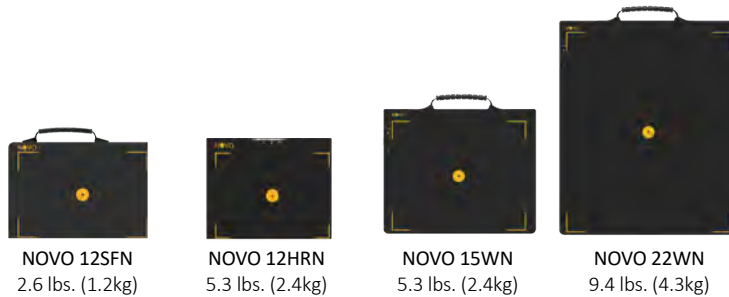

Detector Model	NOVO 12SFN	NOVO 12HRN	NOVO 15WN	NOVO 22WN
Detector Imaging Area	6.75" x 10.1" (17.2cm x 25.8cm)	6.8" x 9.0" (17.3cm x 22.9cm)	9.1" x 11.2" (23.1cm x 28.4cm)	14.0" x 16.8" (35.6cm x 42.7cm)
Active Area (Imaging Area / Detector Size)	80% Active Area	74% Active Area	74% Active Area	85% Active Area
Detector Weight (Including Battery)	2.6 lbs. (1.2kg)	5.3 lbs. (2.4kg)	5.3 lbs. (2.4kg)	9.4 lbs. (4.3kg)
Detector Load Proof	440 lbs. (200kg)	660 lbs. (300kg)	660 lbs. (300kg)	660 lbs. (300kg)
Detector Drop Test	31.5" (80cm)	27.5" (70cm)	20" (50cm)	20" (50cm)
Detector Thickness	0.6" (15mm)	1.1" (27.5mm)	0.6" (15.6mm)	0.6" (15.6mm)
Bit Depth	16 bit latest generation			
Life Span	Over 100K rem*			

NOVO Bendable Detectors



Detector Model	NOVO 10BN	NOVO 18BN
Pixel size	99 microns	99 microns
Net Weight	Sensor: 3.5 lbs. (1.6kg) Electronics Unit: 2.6 lbs. (1.2kg)	Sensor: 3.9 lbs. (1.8kg) Electronics Unit: 2.6 lbs. (1.2kg)
Load Tolerance	220.5 lbs. (100kg)	220.5 lbs. (100kg)
Detector Imaging Area	9.8" X 3.8" (227mm X 98mm) 2299 X 988 pixels	16.33" X 3.82" (415mm X 97mm) 4184 X 981 pixels
Size	Sensor: 17.4" X 7.2" (443mm X 182mm) Electronics Unit: 9.8" X 7.4" (250mm X 188mm)	Sensor: 24.42" X 7.2" (620mm X 182mm) Electronics Unit: 9.8" X 7.4" (250mm X 188mm)
Drop Test	29.5" (75cm)	29.5" (75cm)
Thickness	Sensor: 0.85" (21.5mm) Electronics Unit: 0.8" (20mm)	Sensor: 0.85" (21.5mm) Electronics Unit: 4.72" (120mm)
Bit Depth	16bit	16bit
Life Span	Over 100K rem*	Over 100K rem*
Bending	From flat to 6" diameter (~150mm)	From flat to 12" diameter (~300mm)

* Over 100K rem of direct exposure on the detector

Laptops, Tablets & Smartphones

For detailed information, please review the Bright Tablets / systems brochures

NOVO offers a variety of tablets that can be operated from our customized case or handheld.

- Proprietary high brightness Tablets
- Used to control the system’s operation
- One or multiple parallel location control & display
- Ruggedized Tablets- MIL-STD-810G
- Rugged 7” up to a 21.5” Full HD display
- A variety of Laptops Available
- Windows® 10 & Android OS



NOVO Bright S 10”



NOVO Bright L 17”



NOVO Bright XL 21.5”



Samsung Galaxy S



Variety of Laptops



Panasonic Toughpad™ FZ-G2- 10”



Panasonic Toughbook® CF-33- 12”

Wireless Extenders

Ranger III Mesh

The NOVO Ranger III Mesh is a wireless Mesh transceiver which enables increased wireless stability, speed & range between the tablet and the inspection area.

The Ranger III Mesh can also be used as a relay node or as a Wireless Detector unit when stronger Detector communication is needed.



Wireless Ranger

The NOVO Wireless Ranger is a wireless transceiver, which extends the wireless communication range between the tablet and the inspection area.



Accessories

For detailed information, please review the Accessories brochure

Folding Slider L / XXL

The Ideal Solution for Screening Large & XXL Objects

Folding Slider L Triple Rail

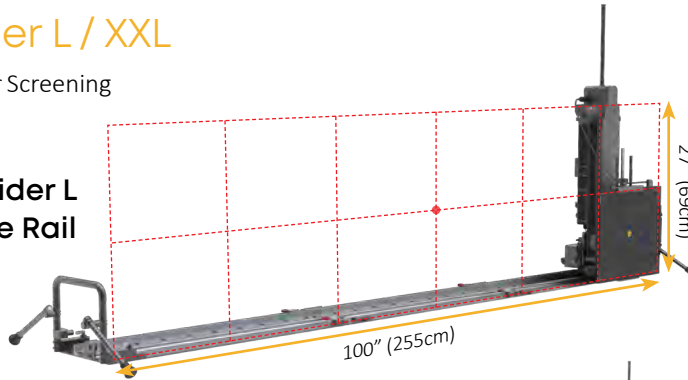

Lifted Mode

Maximum height- 57" (145cm)!

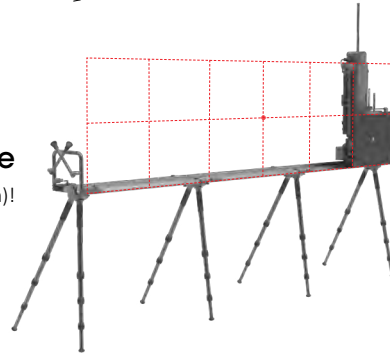

NOVO Mesh Systems

Folding Slider XXL Dual Rail

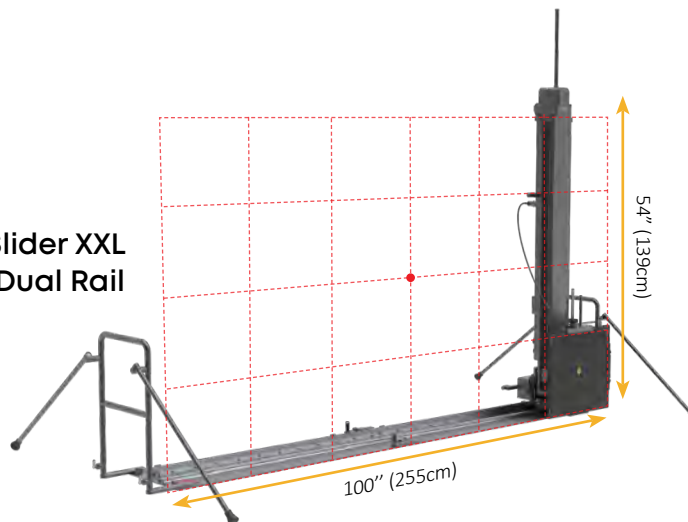

Armor Kit

The Armor Kit Contains the NOVO Armor, which provides additional mechanical protection to the NOVO Detectors, Armor Stand and a traveling soft cover.



Soft Protective Cover

The Detector Soft Protective Cover is a lightweight accessory, which provides impact, heat and liquid protection for NOVO Detectors.



Diagonal Tripod Mounts

The Diagonal Tripod Mount is a lightweight adapter that firmly holds the Detector and provides various positioning options using a tripod or any other custom made fixture.

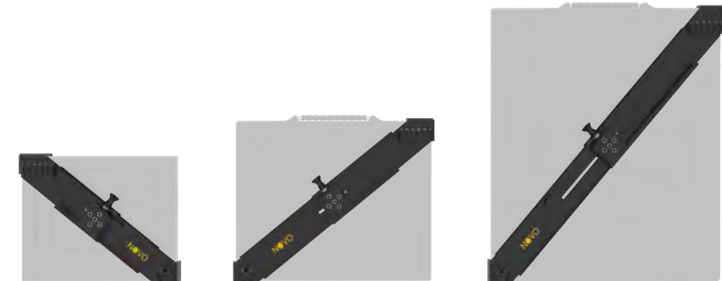

Accessories

Communication Cables

The communication cables provide reliable and fast data transmission between the various system parts.



Extension Reel



Backpack Reel

Pelican Reel



Detector Stand

The Detector Stand is a custom-made accessory that firmly holds the Detector in an upright position (portrait or landscape).

NOVO 12HRN Stand



NOVO 22WN Bipod



Automatic Pipe Scanner

- Can be fitted with NOVO's entire range of Detectors
- Fits pipes from 8" (20.3cm) to 42" (106.7cm")



Wireless X-ray

Enables control of X-Ray generators without an X-Ray sync cable.



Detector Frame

Detector adapter for Manipulators and Mechanical Systems.



Lookout

- Organic detection
- Live Video
- Audio
- LED lights
- Infrared light



Cases & backpacks

NOVO offers a wide array of customized cases for a range of applications.

- Customized internal & external design
- Rugged
- Small foot print
- Lightweight



Discovery III Case



Ultimate III Backpack



Tactical III Backpack



Shadow III Backpack

X-Ray & Isotopes

For detailed information, please review the systems brochures

The NOVO systems are designed to operate with Isotopes, and with most of the existing X-Ray generators in the market, as well as the entire range of Golden Engineering pulsed X-Ray generators.

- Reduced dose, increased safety, improved productivity, prolonged tube life and enable Isotopes usage at a very low activity level
- Operational safety distance is easily obtained with wired or wireless capabilities
- Specially designed connector/picatiny connects the Golden generator to the Controller for quick deployment
- The optional Golden X-Ray generators are portable, battery operated, lightweight & contain no radioactive materials



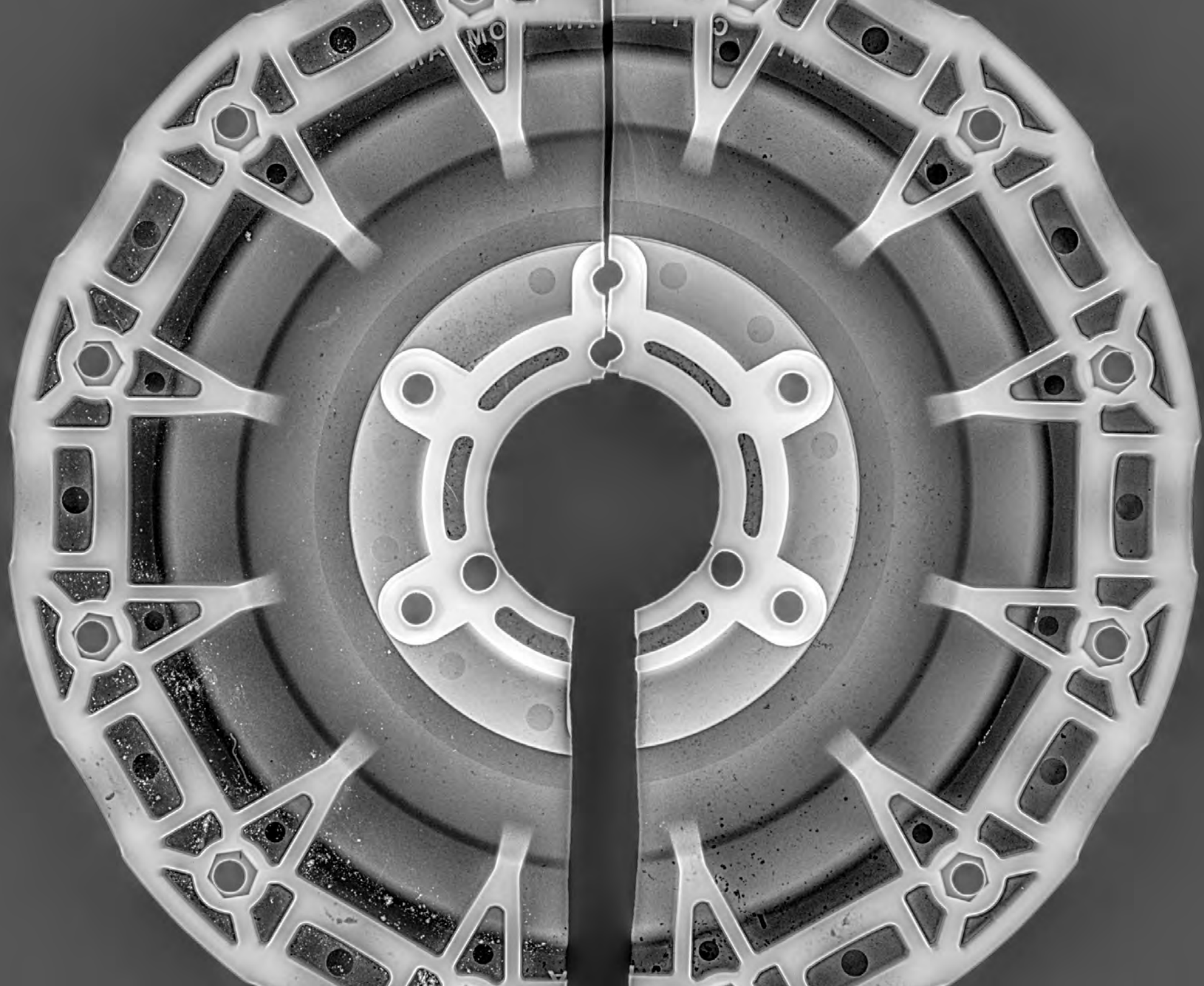

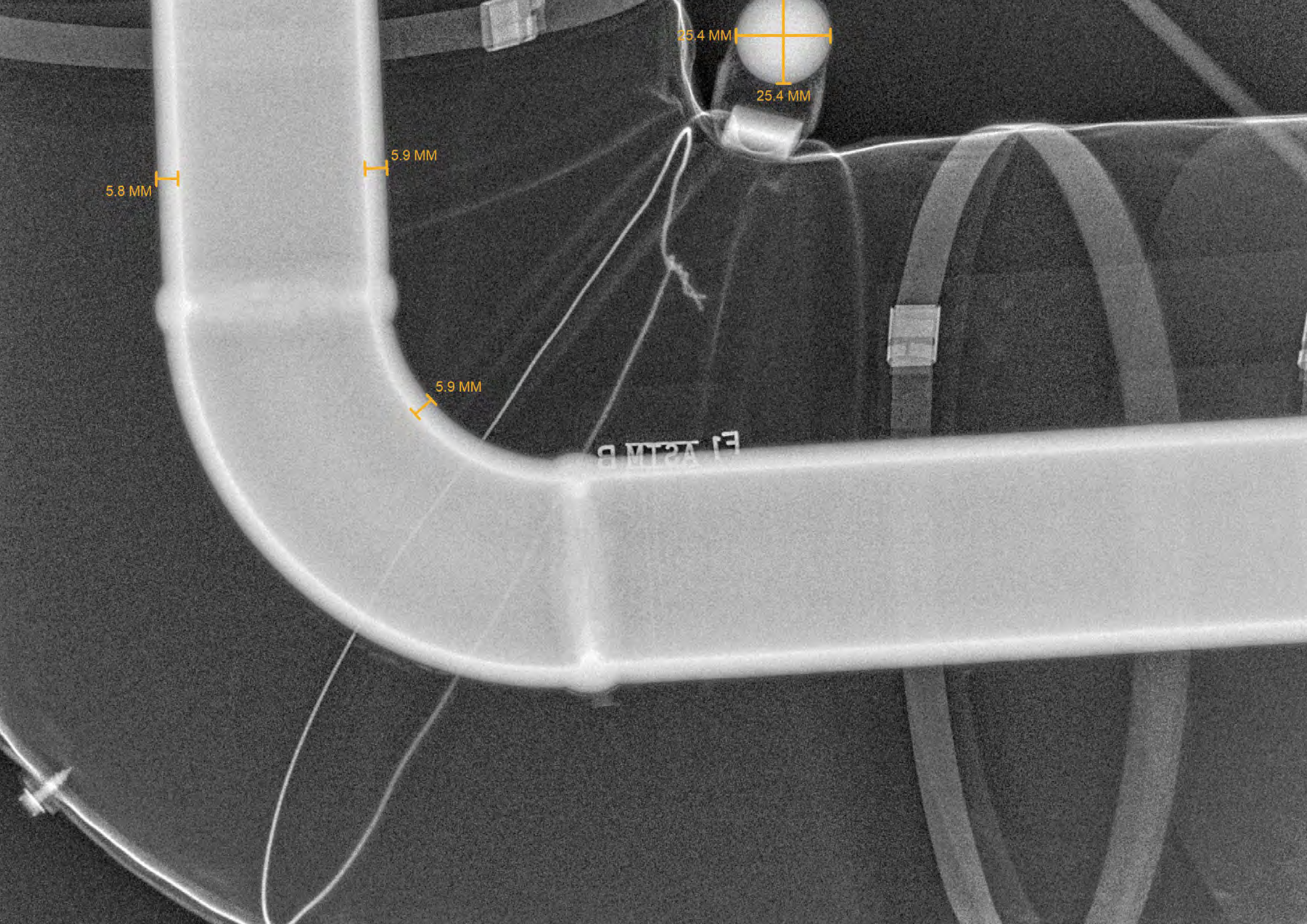

25.4 MM

25.4 MM

5.8 MM

5.9 MM

5.9 MM

E1 251M B

NOVO
Digital Radiography

www.NOVO-DR.com | info@novo-dr.com

**Technical specifications may change at the discretion of the manufacturer*